

Introduction

This instruction sheet contains a parts list and installation information for the Model 4299-1 Single Unit Adjustable Heavy-Duty Rack Mount Kit. This kit includes all hardware necessary to mount one Model 260x SourceMeter® Instrument in a standard 19-inch rack.

Parts list

Table 1 lists the parts supplied with the Model 4299-1 Single Unit Adjustable Heavy-Duty Rack Mount Kit.

Table 1
4299-1 parts list

Quantity	Description	Keithley Part Number
1	Front Rack Ear	2602-333
1	Rear Rack Mount Bracket	2602-334
1	Rack Mount Extension Arm	2602-335
1	Modified Dress Panel	4288-1-301
6	Cage Nut	FA-274
1	"DO NOT DISCARD" Label	MC-345
4	#8-32 X 3/8 LG Phillips Pan Head Screw	8-32X3/8PPH
2	#10-32 X 3/8 LG Phillips Pan Head Sems Screw	10-32X3/8PPHSEM
6	#10-32 X 5/8 LG Phillips Truss Head Screw	10-32X5/8PHTRSH

Installation

The following procedure outlines the installation of the rack mount kit.

WARNING Make sure the instrument that is being installed is in a powered down state with all cables unplugged. Failure to install an instrument in a discharged state may cause an electrical shock or death.

CAUTION To prevent damaging heat build-up, and thus ensure specified performance, adhere to the following rack-mounting precautions:

- Keep the rear exhaust vent and at least one side vent free of any obstructions. Even partial blockage may impair proper cooling.
- DO NOT position a device adjacent to the Model 260x that forces air (heated or unheated) into or onto the Model 260x's cooling vents or surfaces. This additional airflow may compromise accuracy performance.
- Allow at least 1U of space at the top and bottom of the Model 260x (see Note below).
- Make sure there is adequate air flow around at least one side of the instrument. Adequate air flow ensures proper cooling. Adequate airflow provides air temperatures that are within about one inch of the Model 260x surfaces to remain within specified limits under all operating conditions.
- DO NOT rack mount high dissipation equipment adjacent to the Model 260x, which could cause excessive heating to occur. The specified ambient temperature must be maintained around the surfaces of the Model 260x to maintain specified accuracies.

NOTE 1U is a standard vertical spacing and is equal to 1.75 inches. Typical distance between the mounting holes on rack rails is 0.125" (1/8").

When determining placement within any rack, make sure to adhere to the Caution above. If the rack has only convection cooling, use the following as general guidelines to properly design equipment placement:

- Place the hottest equipment (for example, the power supply) at the top of the rack.
- Place precision equipment (such as the Model 260x) as low as possible in the rack (where temperatures are cooler).
- Add space panels below the Model 260x to help ensure adequate air flow.

Step 1. Prepare instrument.

To prepare the instrument for mounting, remove the handle, the mounting ears, and both rear feet. The following information outlines this process.

1. **Remove the handle** —The handle serves as an adjustable tilt-bail. Adjust its position by gently pulling it away from the sides of the instrument case and swinging it up or down. To remove the handle, swing the handle below the bottom surface of the case and back until the orientation arrows on the handles line up with the orientation arrows on the mounting ears (refer to Figure 1). With the arrows lined up, pull the ends of the handle away from the case.
2. **Remove mounting ears.**
 - Remove the screw that secures each mounting ear.
 - Pull down and out to remove each ear.

Figure 1
Remove handle and mounting ears

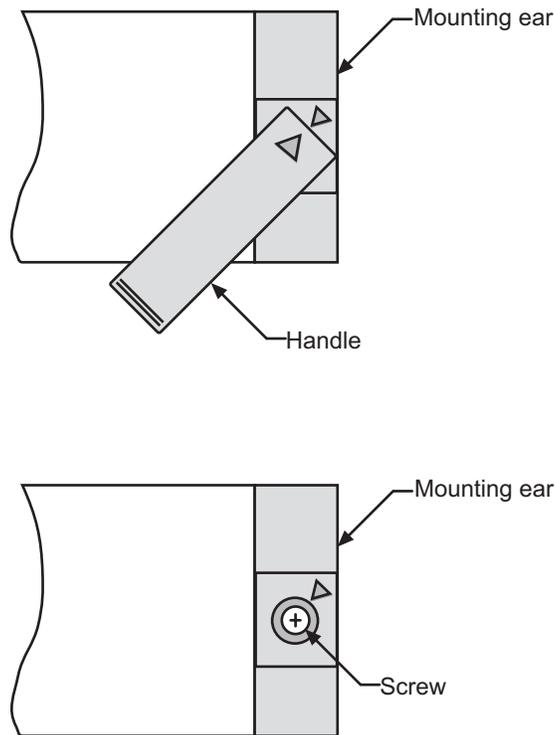

3. **Remove both rear feet from the instrument** by pulling out the rubber feet and then removing the screws underneath.

NOTE *Do not re-install the feet mounting screws. Save all parts removed for future bench top use of the instrument.*

Step 2. Install mounting hardware to instrument.

NOTE *The instrument may be installed on the rack's right side with the dress panel on the left side as shown in the following illustrations, or on the rack's left side with the dress panel on the right side (not shown, but similar).*

1. Determine and select the unit's side that is to be installed closest to the rack rail (see Note above). On the selected side, secure the **Rear Rack Mount Bracket** (2602-334) to the instrument using two **Pan Head Sems Screws** (10-32x3/8PPHSEM) (refer to Figure 2).

Figure 2
Attach rear rack mount bracket to instrument

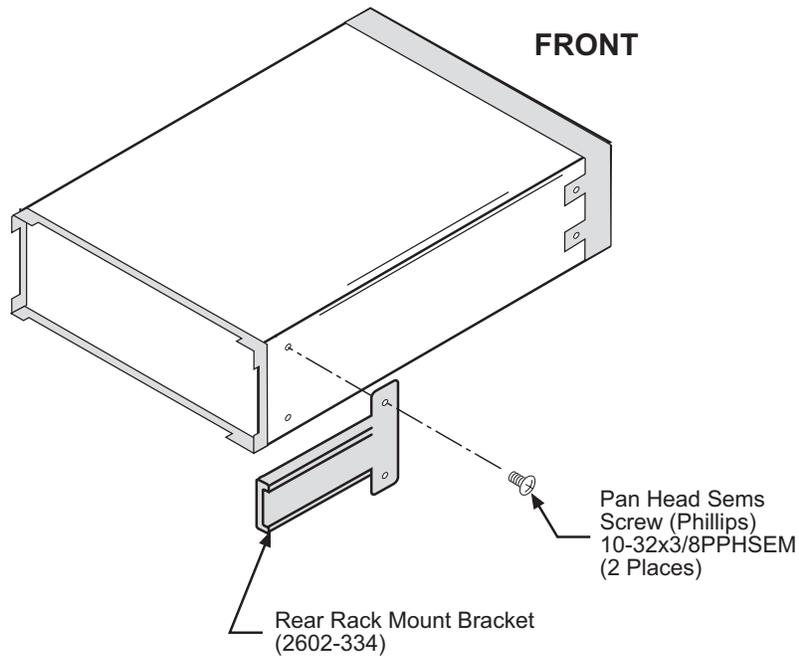

2. Secure **Front Rack Ear** (2602-333) to same side of the instrument as **Rear Rack Mount Bracket** (2602-334) using two **Pan Head Screws** (8-32x3/8PPH) (refer to Figure 3).
3. Secure the **Dress Panel** (4288-1-301) to the other side of the instrument using the two remaining **Pan Head Screws** (8-32x3/8PPH).

Figure 3
Attach rack ear and dress panel to instrument

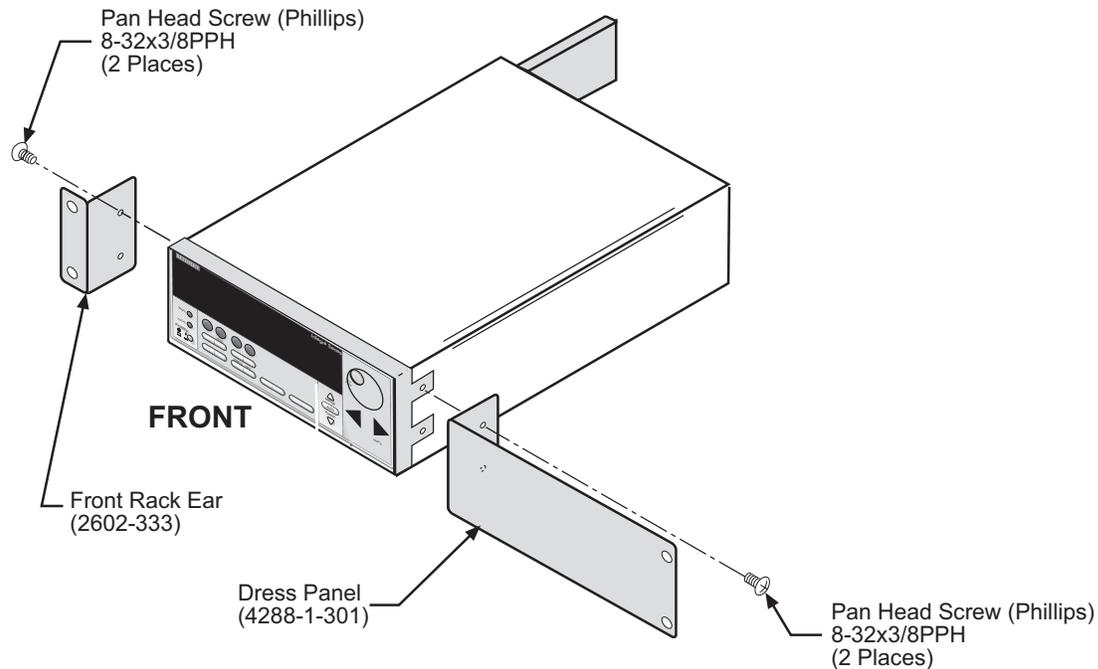

Step 3. Prepare the rack.

1. Install the **Cage Nuts** (FA-274) into the front rack holes for the **Front Rack Ear** and the **Dress Panel** (refer to Figure 4).

NOTE Cage nuts for the front rack ear, dress panel, and rack mount extension arm should be installed into the rails at the same hole spacing (vertical height). Cage nuts for the rack mount extension arm should be installed on the same side as the cage nuts for the front rack ear.

2. Install the **Cage Nuts** (FA-274) into the rear rack holes for the **Rack Mount Extension Arm** (2602-335) on the same side as the **Front Rack Ear** (2602-333). Make sure the locations selected for the rear rack holes correspond to the location selected for the front rack holes.
3. Secure **Rack Mount Extension Arm** (2602-335) to the rear of the rack rail using two **Truss Head Screws** (10-32x5/8PHTRSH).

Figure 4
Attach rack mount extension arm

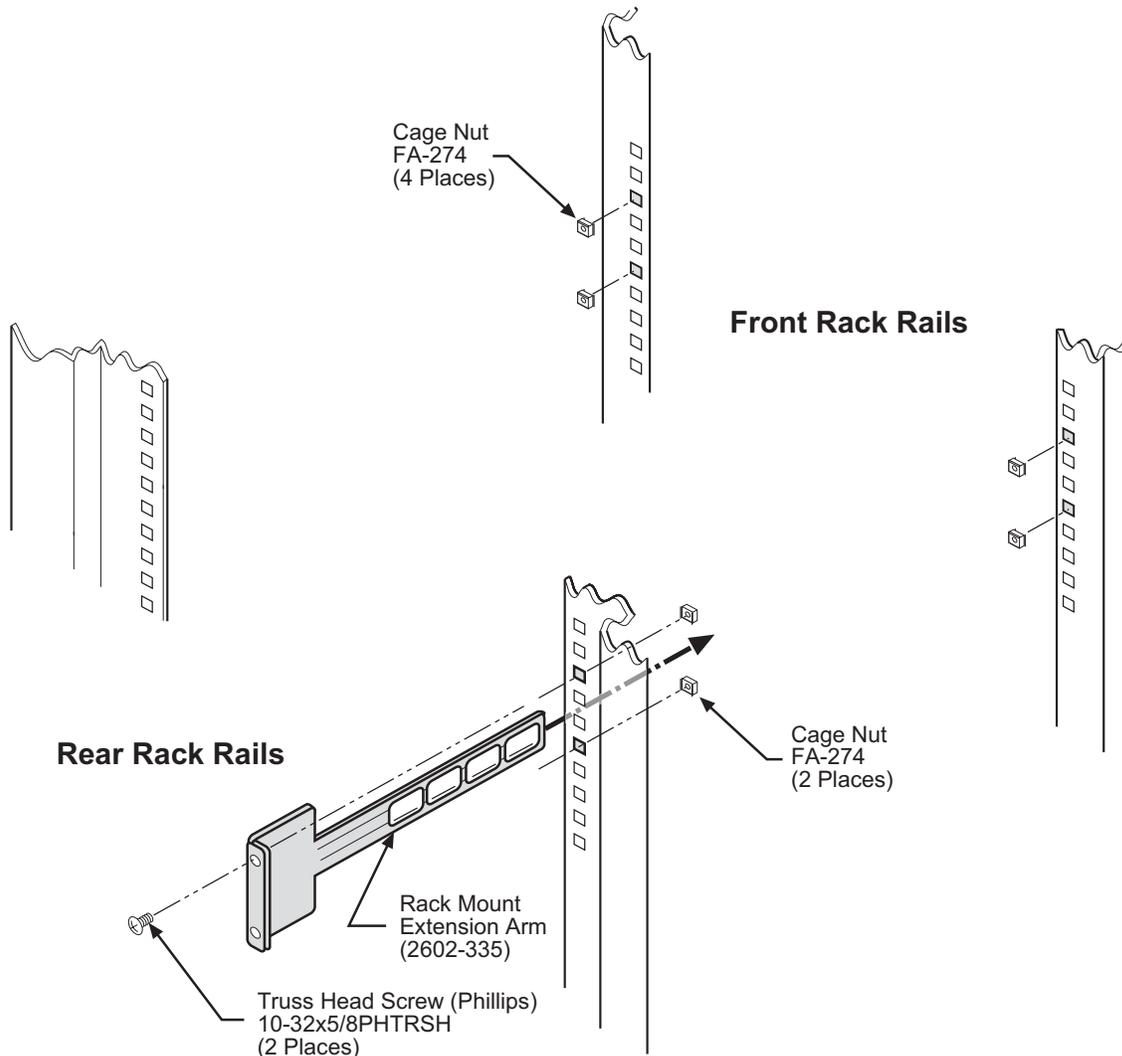

Step 4. Install the instrument.

NOTE When rack mounting restricts access to the main power cord, provide a separate main power disconnect device. This device must be located in close proximity to the equipment and within easy reach of the operator.

1. Slide unit into rack by aligning the **Rear Rack Mount Bracket** (2602-334) with the **Rack Mount Extension Arm** (2602-335) (refer to Figure 5).
2. While still supporting the unit, secure it to the front of the rack with four **Truss Head Screws** (10-32x5/8PHTRSH).

Figure 5
Instrument installation

